

AFR-1
AFS-1

Automatic Water Supply

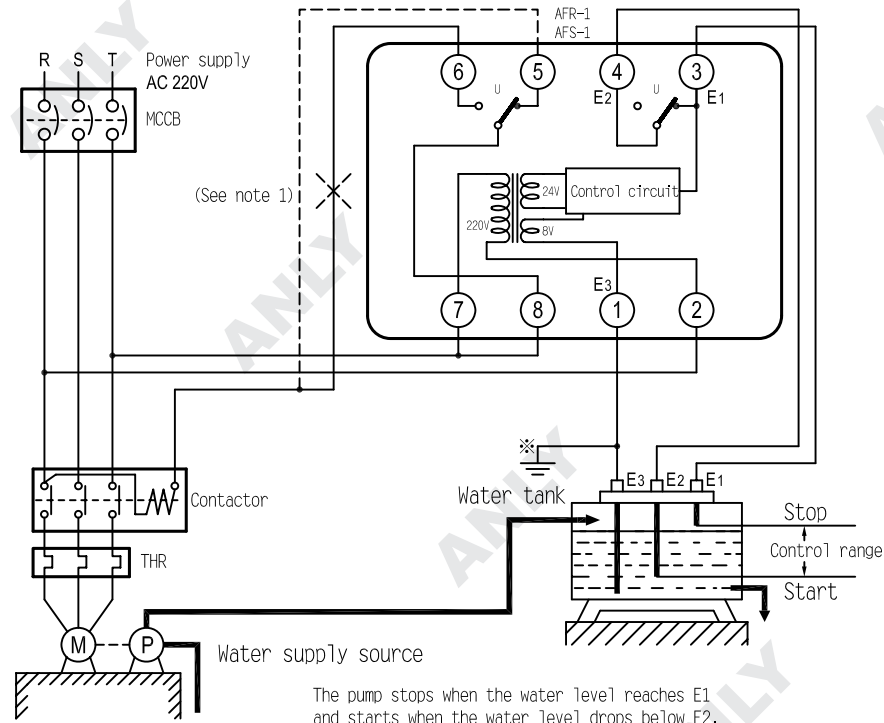

The pump stops when the water level reaches E1 and starts when the water level drops below E2.
 Note: 1.The diagram shows the connections for the water supply.
 When draining, change the connection from terminal 6 to 5.
 2.Be sure to ground terminal E3.

ONLY ELECTRONICS CO.,LTD		
TITLE:AFR-1 and AFS-1 Connection Diagram		
FILE:AFR1_CDe		
DATE:2008.05.19	MATERIAL:	THICKNESS:
SCALE:A4(1:1)	UNIT:	TOLERANCE:
DRAWN BY:Gunter Liu		DESIGNED BY:T. Y. Cheng

A61F-G

Automatic Water Supply

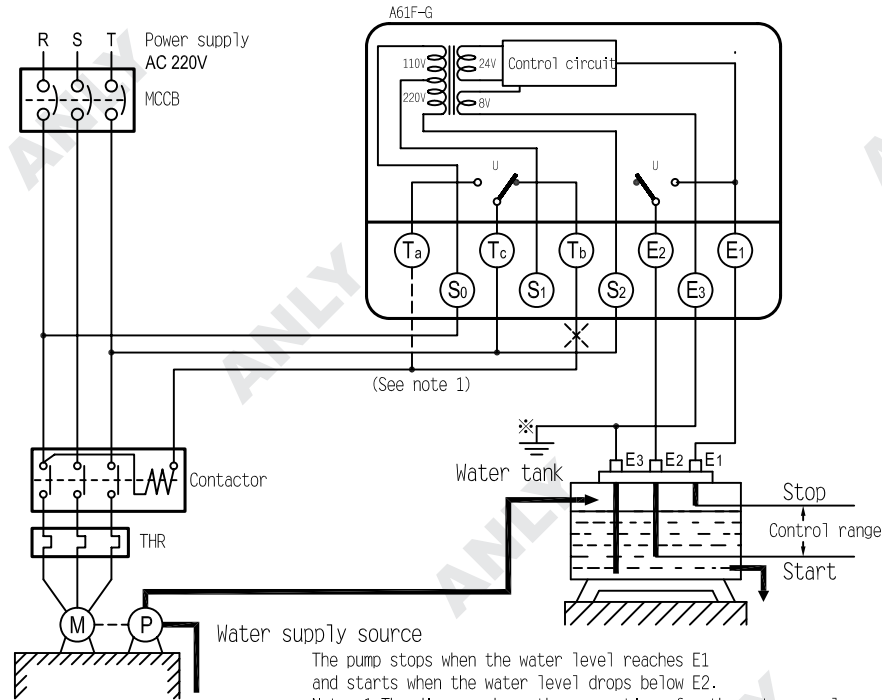

The pump stops when the water level reaches E1 and starts when the water level drops below E2.
 Note: 1.The diagram shows the connections for the water supply.
 When draining, change the connection from terminal Tb to Ta.
 2.Be sure to ground terminal E3.

ONLY ELECTRONICS CO.,LTD		
TITLE:A61F-G Connection Diagram		
FILE:A61FG_CDe		
DATE:2008.05.19	MATERIAL:	THICKNESS:
SCALE:A4(1:1)	UNIT:	TOLERANCE:
DRAWN BY:Gunter Liu		DESIGNED BY:T. Y. Cheng

A61F-G1 Automatic Water Supply Control with Pump Idling Prevention

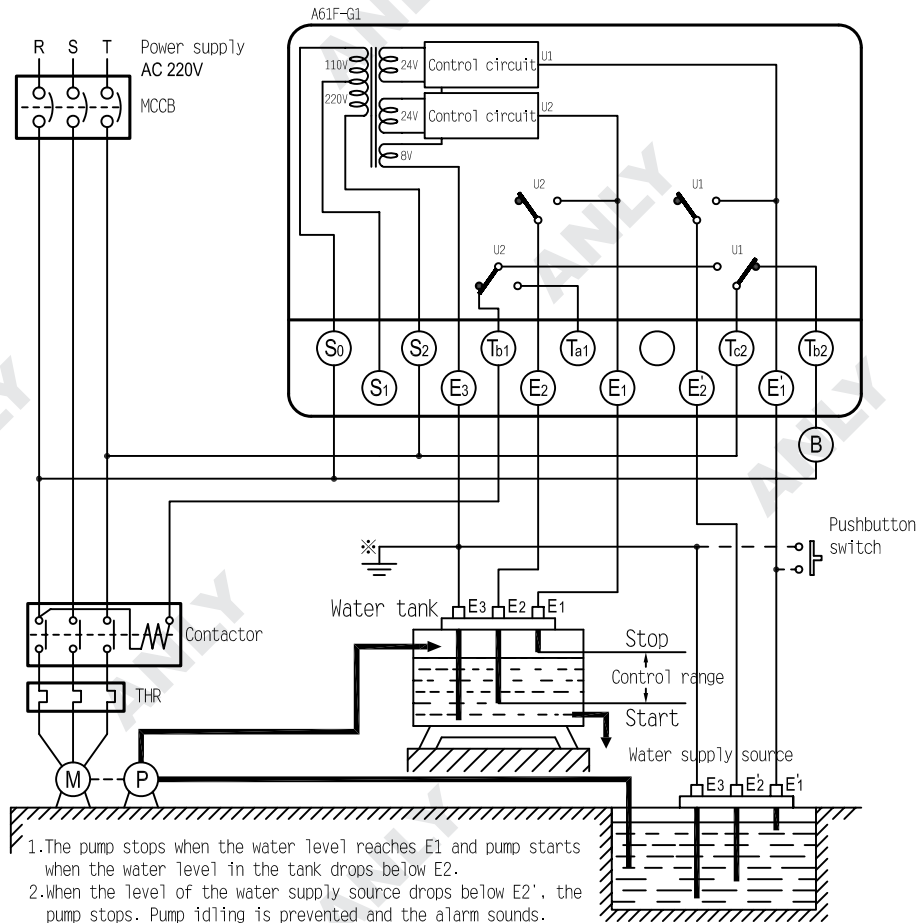

1. The pump stops when the water level reaches E1 and pump starts when the water level in the tank drops below E2.
2. When the level of the water supply source drops below E2', the pump stops. Pump idling is prevented and the alarm sounds.
3. Insert a Pushbutton switch (NO contact) between E1' and E3 as shown by the dotted line. When starting the pump or after recovering from a power failure, if the water supply source level has not yet reached E1', press the pushbutton switch to start the pump by momentarily short-circuiting E1' and E3. When the pump stops during normal operation subsequent to an alarm issued for a low water level (e.g., the water level does not reach E2'), do not press the pushbutton switch.

A61F-G1 Automatic Water Supply Control with Abnormal Water Shortage Alarm

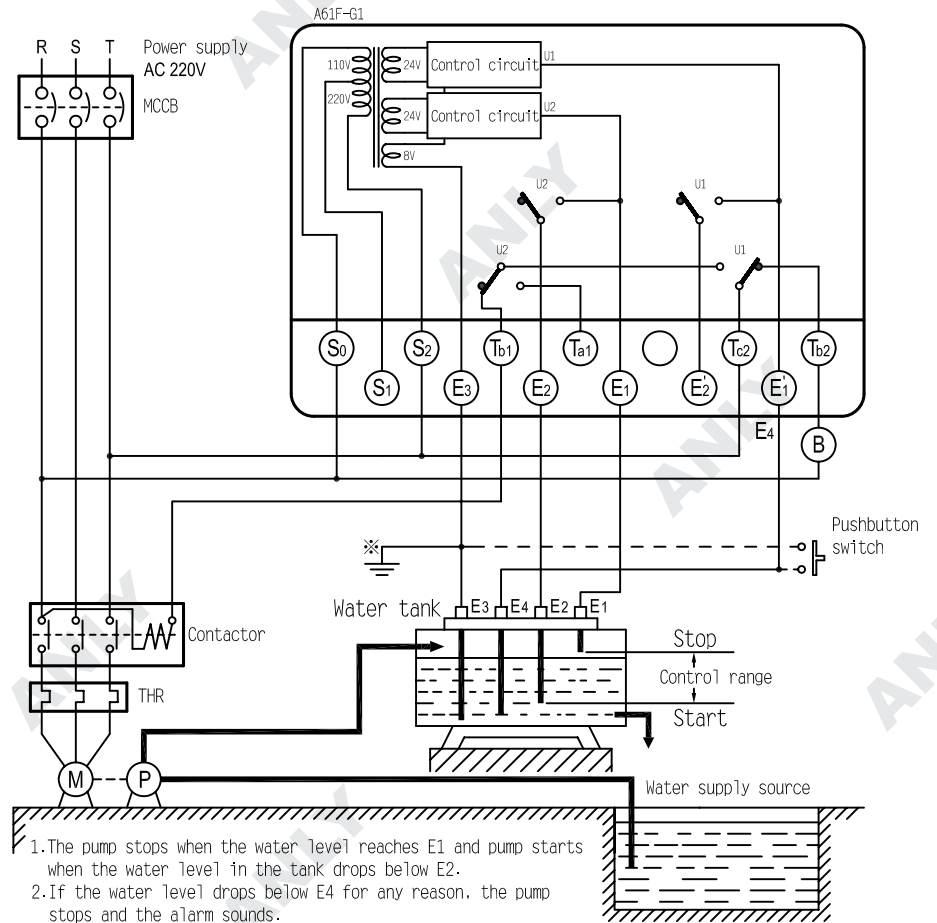

1. The pump stops when the water level reaches E1 and pump starts when the water level in the tank drops below E2.
2. If the water level drops below E4 for any reason, the pump stops and the alarm sounds.
3. Insert a Pushbutton switch (NO contact) between E3 and E4. When starting the pump or after recovering from a power failure, if the water level has not yet reached E4, press the pushbutton switch to start the pump by short-circuiting E3 and E4. If the pump stops upon releasing the pushbutton switch, keep pressing the pushbutton switch.

ONLY ELECTRONICS CO.,LTD

TITLE: A61F-G1 Connection Diagram

FILE: A61FG1_CDe

DATE: 2008. 05. 19

MATERIAL:

THICKNESS:

SCALE: A4(1:1)

UNIT:

TOLERANCE:

DRAWN BY: Gunter Liu

DESIGNED BY: T. Y. Cheng

A61F-G2 Automatic Drainage Control with Abnormal Water Increase Alarm

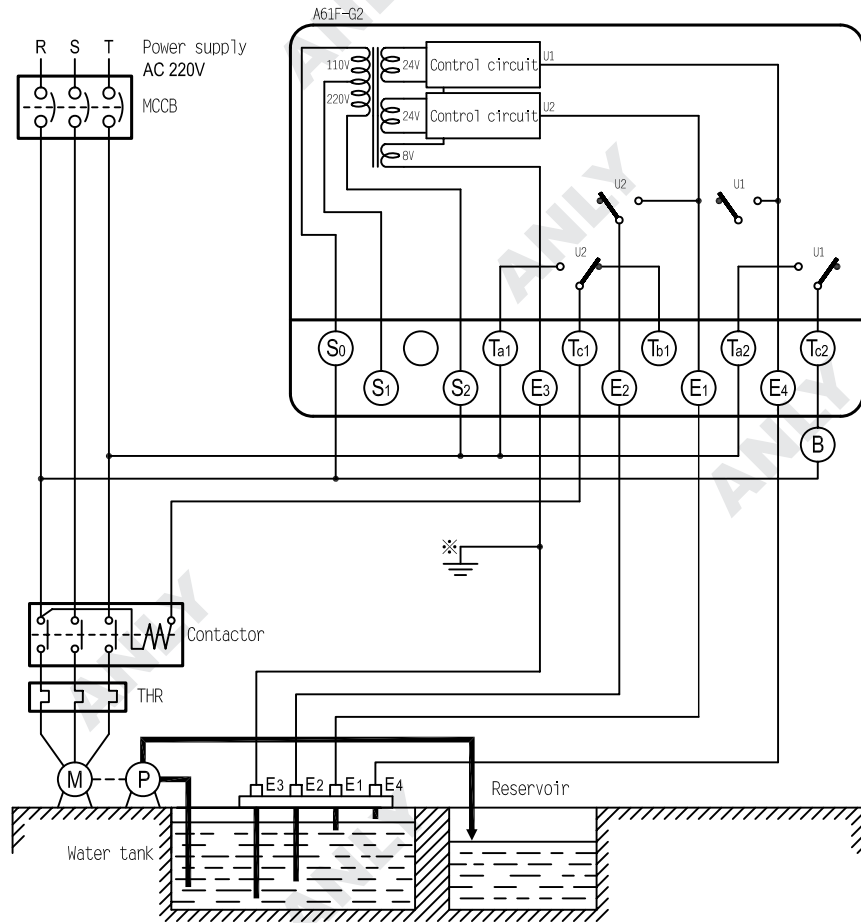

1. The pump starts when the water level reaches E1, E2 and stops when the water level drops below E2.
2. If the water level reaches E4 for any reason, the alarm sounds.

A61F-G2 Automatic Water Supply with Abnormal Water Increase Alarm

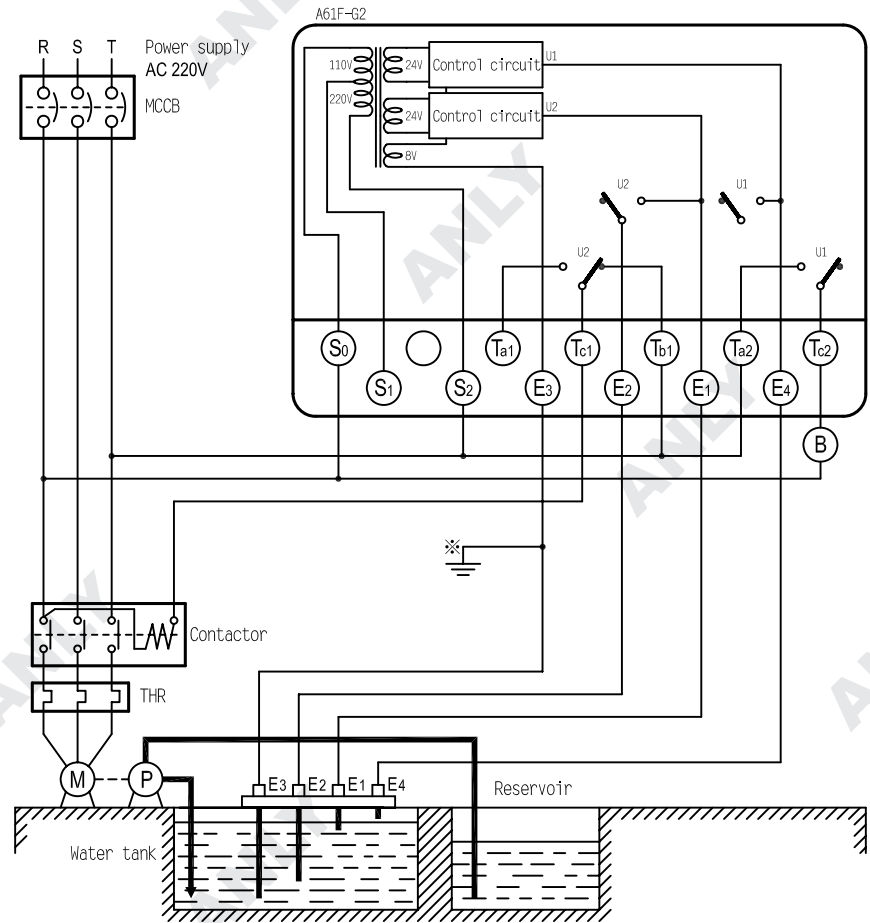

1. The pump starts when the water level reaches E2 and stops when the water level rises to E1.
2. If the water level reaches E4 for any reason, the alarm sounds.

ONLY ELECTRONICS CO.,LTD

TITLE: A61F-G2 Connection Diagram

FILE: A61FG2_CDe

DATE: 2008. 05. 19

MATERIAL:

THICKNESS:

SCALE: A4(1:1)

UNIT:

TOLERANCE:

DRAWN BY: Gunter Liu

DESIGNED BY: T. Y. Cheng

Water-supply running

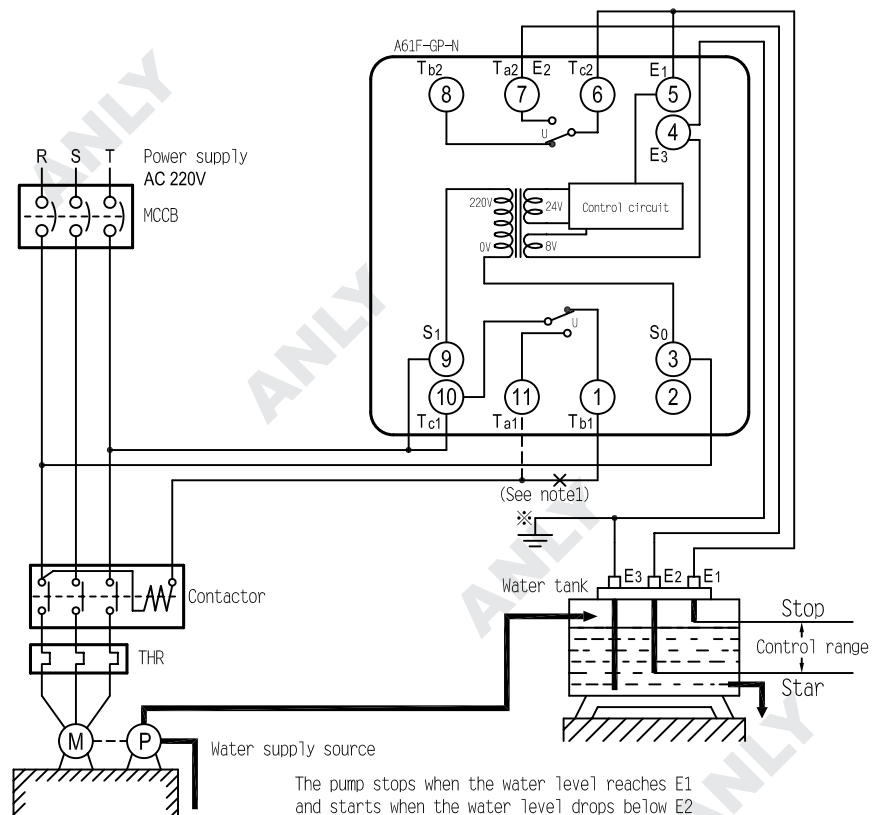

The pump stops when the water level reaches E1 and starts when the water level drops below E2

Note: 1.The diagram shows the connections for the water supply.

When draining, change the connection from terminal 1 to 11.

2.Be sure to ground terminal E3.

ONLY ELECTRONICS CO.,LTD

TITLE:A61F-GP-N Connection Diagram

FILE:A61FGPN_CDe

DATE:2008.05.19

MATERIAL:

THICKNESS:

SCALE:A4(1:1)

UNIT:

TOLERANCE:

DRAWN BY:Gunter Liu

DESIGNED BY:T. Y. Cheng