



ANLY TEMPERATURE CONTROLLER

AT02B PID TEMPERATURE CONTROLLER



CHARACTERISTICS :

- Easy-to-use, PID function selectable
- Relay or SSR output, selectable via DIP switch for output1
- Can chose one of them : Relay, Alarm2, RS485, 4~20mA and SSR for output2
- Accepts thermocouple, platinum RTD or 4~20mA* inputs
- Heating or cooling control selectable
- Panel lock protection function
- Sensor malfunction detection function
- Available in 4 sizes : 48 x 48mm(1/16DIN), 48 x 96mm(1/16DIN), 72 x 72, 96 x 96mm(1/4DIN)

Note. It depend on what input type do you select.

TYPE SELECTION :

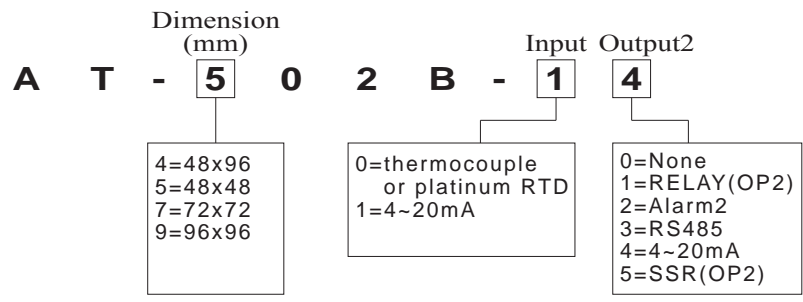

SPECIFICATIONS :

Type	AT-402B, AT-502B, AT-702B, AT902B		
Operating voltage	AC/DC(V) : 100 - 240		
Rated frequency	50 / 60 Hz		
Power consumption	Approx. 3.5VA		
Input	-□02B-0□	Thermocouple	K, J, R
		RTD	Pt100
	-□02B-1□	Analog	Current(4~20mA)
Output1	SW5 OFF	Relay	240VAC 3A, resistive load
	SW5 ON	SSR	DC 24V
Output2	-□02B-□1	Relay(OP2)	240VAC 3A, resistive load
	-□02B-□2	Alarm2(Relay)	240VAC 3A, resistive load
	-□02B-□3	Communication	RS-485
	-□02B-□4	Linear	Current(4~20mA)
	-□02B-□5	SSR(OP2)	DC 24V
Alarm1 output	Relay (240VAC 3A, resistive load)		
Alarm function	See figure 1		
Control method	PID, PI, P, ON/OFF, Dead Band		
Setting	Digital setting using front panel keys		
Indicator	7-segment-display and LED		
Ambient temperature	-10 ~ +50°C (without condensation & freezing)		
Storage temperature	-25 ~ +65°C		
Ambient humidity	35 ~ 80%RH (without condensation)		
Storage humidity	35 ~ 95%RH		
Altitude	MAX 2000m		
Weight	AT-402B Approx. 195g, AT-502B Approx. 150g, AT-702B Approx.210g , AT-902B Approx. 255g		

FEATURES :

Type	AT-402B, AT-502B, AT-702B, AT902B
Measuring accuracy	Within $\pm 0.3\%$ of present value or $\pm 2^\circ\text{C}$ whichever is greater
Proportional band (P)	0.1 ~ 3000 (0.1 units)
Integral time (I)	0 ~ 7200sec (1-second units)
Derivative time (D)	0 ~ 1800sec (1-second units)
Control period	0 ~ 65sec (1-second units)
Sampling period	250ms
Memory protection	EEPROM non-volatile memory (writing times : Approx. 100,000times)

FIGURE 1 (ALARM FUNCTION) :

AF1	Alarm function selection
1	Deviation high alarm
2	Deviation low alarm
3	Process high alarm
4	Process low alarm
5	Deviation high/low alarm
6	Band alarm
7	Deviation high alarm (standby)
8	Deviation high alarm (standby)
9	Process high alarm (standby)
10	Process low alarm (standby)
11	Deviation high/low alarm (standby)
12	Band alarm (standby)

CONNECTION :

AT-402B / 902B

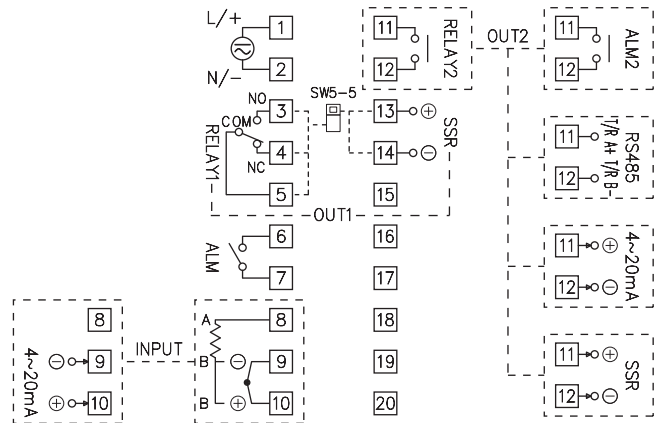

AT-502B

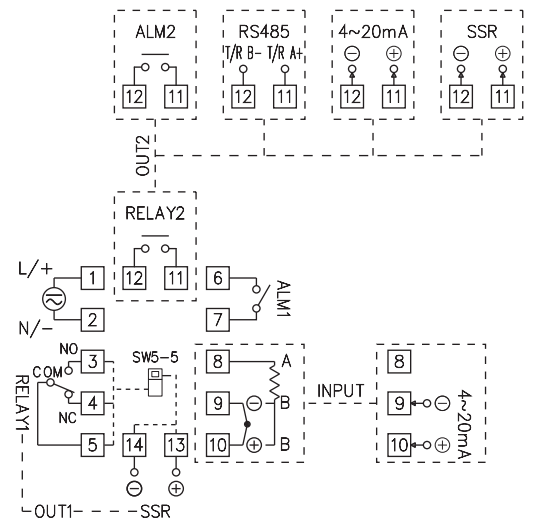

AT-702B

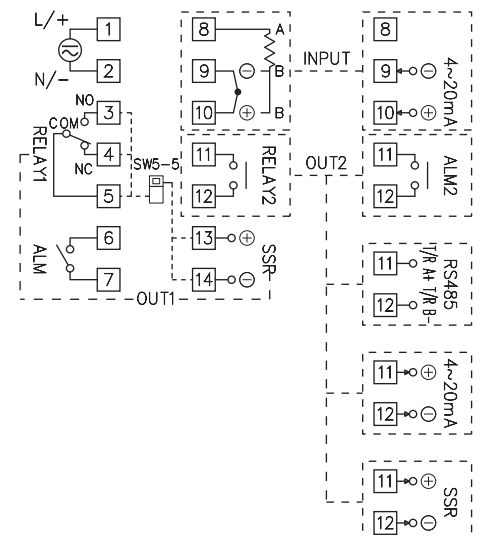

RATED SCALE :

Input type	°C	°F
K	0~1200	32~2192
J	0~500	32~932
R	0~1700	32~3092
PT-100	-50~400	-122~752

DIMENSIONS : (mm)

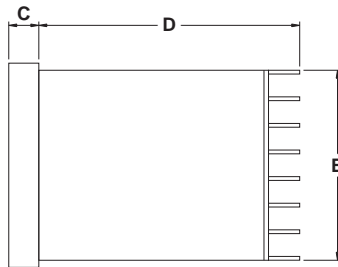
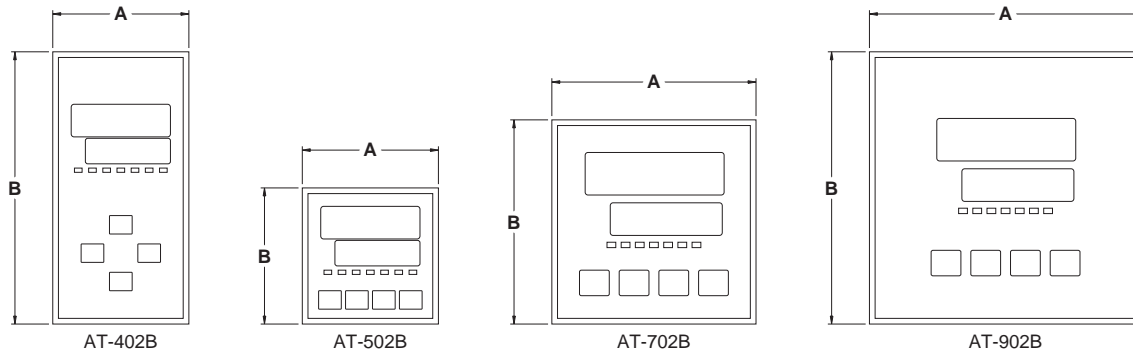

	A	B	C	D	E
AT - 402B	48	96	8.0	83	90
AT - 502B	48	48	8.0	83	44.5
AT - 702B	72	72	8.0	83	66.5
AT - 902B	96	96	8.0	83	90

PANEL CUTOUT DRAWING : (mm)

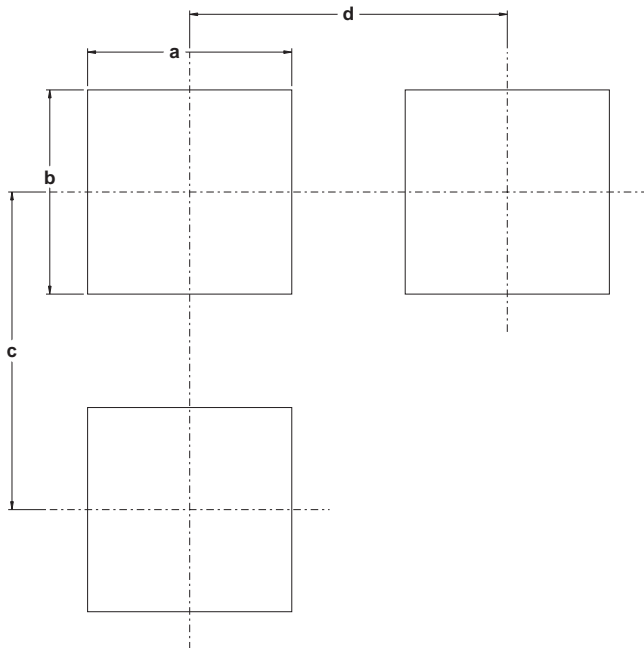

	a	b	c	d
AT - 402B	45.5 ^{+0.5} ₋₀	91 ^{+0.5} ₋₀	120	70
AT - 502B	45.5 ^{+0.5} ₋₀	45.5 ^{+0.5} ₋₀	70	70
AT - 702B	67.5 ^{+0.5} ₋₀	67.5 ^{+0.5} ₋₀	100	100
AT - 902B	91 ^{+0.5} ₋₀	91 ^{+0.5} ₋₀	120	120

ONLY ELECTRONICS CO., LTD.

<http://www.ONLY.com.tw>

TAIWAN MAIN OFFICE : ONLY ELECTRONICS CO., LTD.

No.19, Lane 202, Fushou St., Xinzhuang Dist., New Taipei City 242, Taiwan
 TEL: +886-2-2996-3202 FAX: +886-2-2996-2017

MALAYSIA BRANCH : JUSTY ELECTRONICS (M) SDN, BHD.

No.1, Jalan 6/89B, Kawasan Perindustrian Trisegi, Batu 3 1/2 Off Jalan Sungei Besi, 57100 Kuala Lumpur, Malaysia
 TEL: +60-3-7983-5758 FAX: +60-3-7981-5052

HONG KONG BRANCH : ONLY ELECTRONICS (HK) LTD.

Flat K, 13/F, Edward Mansion, 141 Prince Edward Road W., Kowloon, Hong Kong
 TEL: +852-2397-2505 FAX: +852-2397-6080

SHANGHAI BRANCH : ONLY TECHNOLOGY (WUXI) CO., LTD.

Room 13G, No.831, Xinzha Rd., Jingan District, Shanghai, China 200041
 TEL: +86-21-6218-3300 FAX: +86-21-6217-5911